

Technical Datasheet - Stair Nosing

Aluminium Retro Fit - NRA

Product Description

Genesis NRA profile is a strong well designed, innovative Aluminium profile designed to provide a simple, safe secure edge for steps covered in ceramic tiles or similar.

The profile sits on top of the floor covering providing a perfect step edge with a grooved profile face for extra grip.

Dimensions and Colour

The profiles dimensions are 50mm wide tread and 30mm front face, and a 25mm wide tread and a 19mm front face.

The profile NRA50 is available in a Mill Aluminium (80) , and the profile NRA25 is available in Matt Silver (81) and Matt Brass (83)

Range

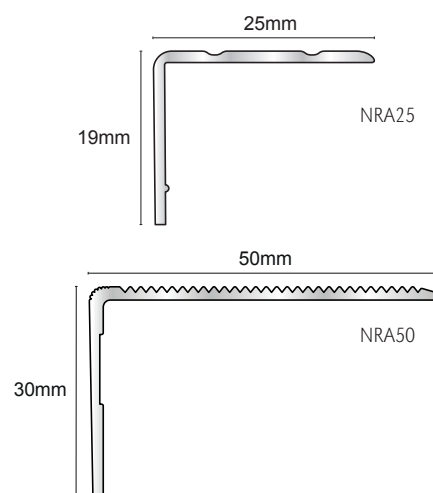

Aluminium AA 6063 T6 / UNS A96063 anodised to DIN 17611	
Si%	0.2-0.6
Fe%	0.35
Cu%	0.1
Mn%	0.1
Mg%	0.45-0.9
Zn%	0.1
Ti%	0.1
Cr%	0.1
Al	Balance

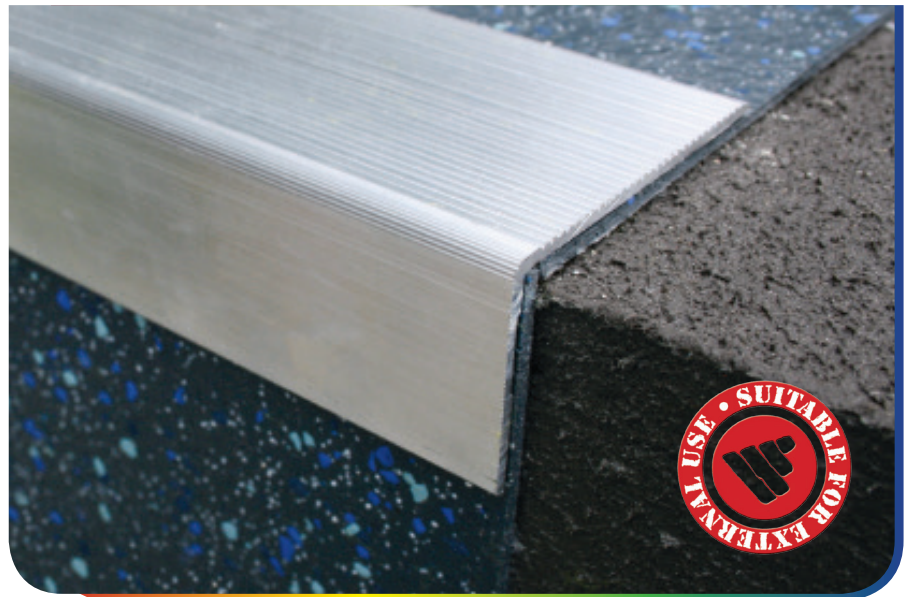

Maintenance

Genesis NRA does not require any special maintenance. Oxidisation film on Aluminium may be removed with a common polishing agent; however, they do reoccur.

Damaged anodised finishes may only be repaired by re-coating. Aluminium must be tested to verify its suitability if chemical stresses are anticipated. Cementitious materials, in conjunction with moisture, become alkaline. Since aluminium is sensitive to alkaline substances, exposure to the alkali (depending on the concentration and time of exposure) may result in corrosion (aluminium hydroxide formation). Therefore, it is important to remove adhesive or grout residue from visible surfaces. In addition ensure that the profile is solidly embedded in the setting material and that all cavities are filled to prevent the collection of alkaline water. The anodised layer creates a finish that retains a uniform appearance during normal use. The surface, however, is susceptible to scratching and wear and may be damaged by tile adhesive, mortar, or grouting material. Therefore, setting materials must be removed immediately. Otherwise, the description regarding Aluminium applies.

Technical Details

Genesis Aluminium Profiles are available in different anodised finishes and powder coated finishes - All natural Aluminium (Mill Finish) has an oxide film of approx 0.2 microns, when Mechanically & Chemically polished the anodising process increases this to 5 microns, up-to 20 microns for the Matt finish and 100 for Powder coated

Installation

1. Check the fit of the nosing and ensure that the profile is firmly placed against the riser of the step, if required mark the floor.
2. Drill the sub floor and plug accordingly. (If screw fixing is desired)
3. Apply any contact grade adhesive to the bottom of the profile and to the tread where the nosing is to be fixed.
4. Place the nosing in position and leave to set.

P.V.C. Trim • Stair Nosings • Expansion Joints • Transitions • Seals • Edge Protection • Metal Trim • Skirting • Tools

Tel: +44 (0)1642 713000

Email: info@genesis-gs.com

www.genesis-gs.com

UK Head Office & Factory
Stokesley Business Park Stokesley
North Yorkshire TS9 5JZ UK



Genesis
For the Perfect Finish

